



<http://www.cubesatkit.com/>

CubeSat Kit™

Battery Module 1 (BM 1)

Hardware Revision: A

Dual Protected Li-Ion Battery Module with Supervisor & Telemetry

Applications

- CubeSat nanosatellite batteries
- General-purpose energy storage in a PC/104-size form factor
- Remote sensing for harsh environments

Features

- Dual Li-Ion batteries
- Two 18650 Li-Ion cells per battery (2S2P)
- 40Wh energy storage (20Wh + 20Wh)
- High power (5A output per battery)
- Independent protection circuitry for each battery
- Provides overcurrent (OC), overvoltage (OV), overtemperature (OT), undervoltage (UV) & undertemperature (UT) protection
- Additional features via PIC24E supervisor MCUs:
 - Battery heaters
 - Battery protection status telemetry
 - Battery voltage, current and temperature telemetry
 - Battery protection trip & override
 - Supervisor MCU temperature & status
 - I2C command & telemetry interface
 - Serial interface for debugging, etc.
 - Status LEDs
- Extremely low (<TBD μ A) quiescent current
- Selectable OC trip thresholds
- Stackable
- MOSFET-based power switching, with interface to Remove-Before-Flight (RBF) and Separation switches of CubeSat Design Specification (CDS)

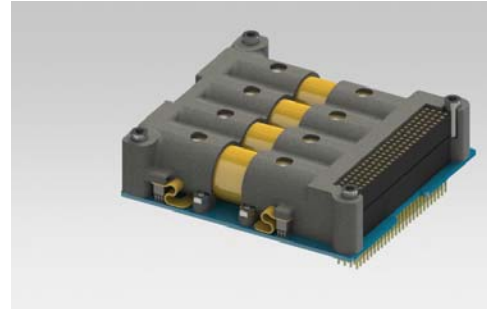

ORDERING INFORMATION

Pumpkin P/N 710-01006

Contact factory for availability of optional configurations.
Default configuration shown.



CAUTION

Electrostatic
Sensitive
Devices

Handle with
Care



CHANGELOG

Rev.	Date	Author	Comments
A0	20130724	AEK	Initial draft.
A	20130726	AEK	Initial (preliminary) release. Various added parameters, plus block diagram.
B	20140209	AEK	Removed block diagram.

OPERATIONAL DESCRIPTION

The CubeSat Kit™ Battery Module 1 (BM 1) incorporates and protects two independent 7.4V Li-Ion 18650 batteries from overcurrent (OC), overvoltage (OV), overtemperature (OT) and undervoltage (UV) conditions. The batteries – each with two cells (nom. 3.7V) in series – are connected to the CubeSat Kit Bus Connector for use with Electrical Power Systems (EPS) designed for Lithium-chemistry batteries.

Each 20Wh battery consists of two 18650 Li-Ion cells connected in series (2S1P). The two batteries – comprising 40Wh of storage in total – operate completely independently of each other, sharing only their (protected) – and + terminals. To the CubeSat, the two batteries of the Battery Module appear as being effectively connected in parallel (2S2P).

Each pair of 18650 cells is connected to its own dedicated battery protection circuit consisting of a dual-cell Li-Ion battery protection chip and related components (e.g., power MOSFETs). This protection circuitry automatically and autonomously disconnects the battery from any load when an OC, OV and/or UV fault condition is detected, independent of the supervisor MCU (see below) and the actions of an external charger. Such conditions can occur e.g. from load short circuits, battery charger malfunctions, and inadvertent battery depletion.

Each battery protection circuit independently controls the charge and discharge paths through its battery. Faults are handled either internally and automatically, or externally via intervention by the Supervisor MCU, as described below:

- OC: Charge and discharge are disabled. This fault state remains latched until the OC condition is removed and the supervisor MCU resets the latch.
- OV: Charge and discharge are disabled until the OV condition is removed. This is a non-latching fault condition.
- OT: Charge and discharge is disabled until the battery temperature falls to within an acceptable range, whereupon the supervisor MCU resets this fault.
- UV: Discharge is disabled until the battery rises above the UV threshold.¹ This is a non-latching fault condition. The battery can be charged in the UV condition.
- UT: Charge and discharge are disabled until the battery's temperature rises above the UT threshold. If power is available (either via the batteries themselves or via the external charger's input to the BM), the supervisor MCU will enable the battery heaters in an attempt to raise the battery temperature.

Each battery has a dedicated nanopower supervisor MCU that interfaces to the battery protection circuit and to the CubeSat Kit's I2C interface. Each supervisor MCU – in addition to providing battery voltage, current and temperature telemetry – monitors the state of the autonomous battery protection circuitry and can both trip (i.e., invoke the OC fault state) and reset the battery protection. Additionally, each supervisor MCU is responsible for monitoring for OT faults. Each supervisor MCU is active at all times, operating at different levels of functionality depending on the amount of power available. Each supervisor MCU acts as an I2C slave so as to provide telemetry to and accept commands from the host.

The Battery Module provides neither battery charging features nor any regulated outputs – these are the responsibilities of a separate EPS. A typical EPS host implementation is a CC/CV battery charger for Lithium battery chemistries, with a maximum voltage of 8.25Vdc applied to the batteries, along with regulated and current-limited outputs for +5Vdc and +3.3Vdc.

¹ Subject to hysteresis.

ABSOLUTE MAXIMUM RATINGS

Parameter	Symbol	Value	Units
Operating temperature ²	T_A	-40 to +85	°C
Voltage on +5V <u>BUS</u> bus		-0.3 to +14.5	V
Voltage on 3V3 <u>BUS</u> bus		-0.3 to +5.5	V
Voltage via USB		-0.3 to +5.5	V
Voltage on <u>VBAT</u>		-0.3 to TBD	V
Current into or out of any battery		TBD	A

² Does not apply to the batteries themselves. Most Li-Ion batteries have a much narrower operational and storage temperature range (typically 0C to 45C). The BM 1 will attempt to keep the batteries above freezing (0C) at all times. The BM 1 cannot cool the batteries.

PHYSICAL CHARACTERISTICS

Parameter	Conditions / Notes	Symbol	Min	Typ	Max	Units
Mass				310		g
Height of components above PCB					21.75	mm
Height of components below PCB					1.75	mm
PCB width				96		mm
PCB length				90		mm
PCB thickness				1.6		mm
CubeSat Kit Bus Connector terminal pitch	Horizontal or vertical distance to nearest terminal		2.54			mm

SIMPLIFIED MECHANICAL LAYOUT ³

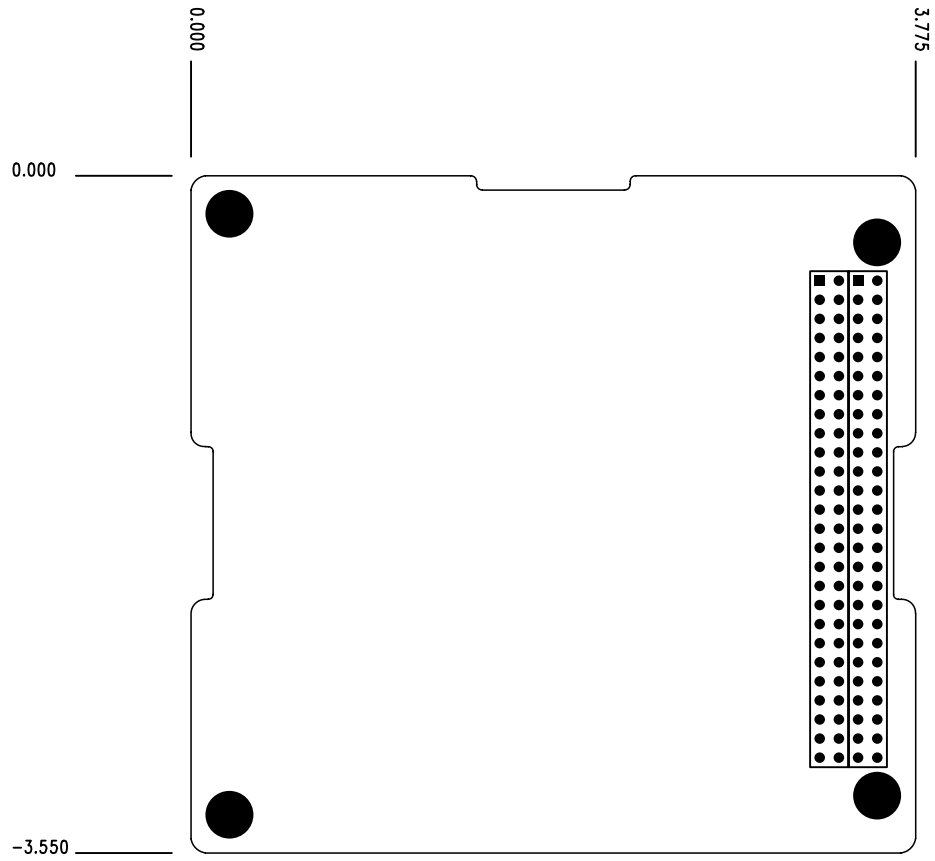

³ Dimensions in inches.

ELECTRICAL CHARACTERISTICS

(T = 25°C, +5V bus = +5V unless otherwise noted)

Parameter	Conditions / Notes	Symbol	Min	Typ	Max	Units
Energy storage	With four 18650 Li-Ion cells			40		Wh
Overcurrent fault	Trip	$V_{OC\ TRIP}$		5		A
	Reset	$V_{OC\ RESET}$		0		A
Overvoltage fault	Trip	$V_{OV\ TRIP}$		8.40		V
	Reset	$V_{OV\ RESET}$		8.30		V
Overtemperature fault	Trip	$T_{OT\ TRIP}$		TBD		C
	Reset	$Y_{OT\ RESET}$		TBD		C
Undervoltage fault	Trip	$V_{UV\ TRIP}$		5.00		V
	Reset	$V_{UV\ RESET}$		6.20		V
Undertemperature fault	Trip	$T_{UT\ TRIP}$		TBD		C
	Reset	$T_{UT\ RESET}$		TBD		C
Operating current	Typical operation	I_{OP}		TBD		μA
	Supervisor MCU asleep	I_{SLEEP}		TBD	TBD	μA

CubeSat Kit Bus PIN DESCRIPTIONS

CubeSat System Bus

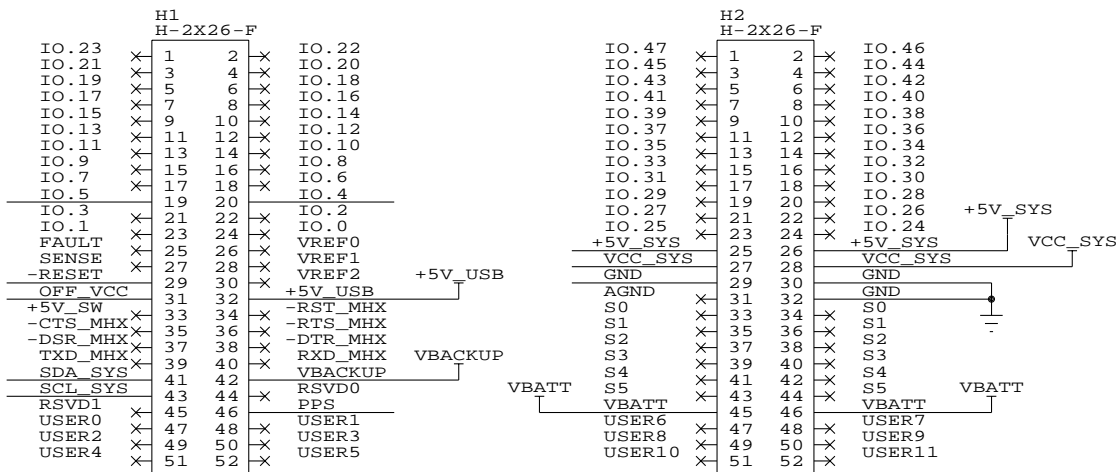

CubeSat Kit Bus PIN DESCRIPTIONS – I/O

Name	Pin	I/O	Description
IO.0	H1.24		Not connected.
IO.1	H1.23		Not connected.
IO.2	H1.22		Not connected.
IO.3	H1.21		Not connected.
IO.4	H1.20		Not connected.
IO.5	H1.19		Not connected.
IO.6	H1.18		Not connected.
IO.7	H1.17		Not connected.
IO.8	H1.16		Not connected.
IO.9	H1.15		Not connected.
IO.10	H1.14		Not connected.
IO.11	H1.13		Not connected.
IO.12	H1.12		Not connected.
IO.13	H1.11		Not connected.
IO.14	H1.10		Not connected.
IO.15	H1.9		Not connected.
IO.16	H1.8		Not connected.
IO.17	H1.7		Not connected.
IO.18	H1.6		Not connected.
IO.19	H1.5		Not connected.
IO.20	H1.4		Not connected.
IO.21	H1.3		Not connected.
IO.22	H1.2		Not connected.
IO.23	H1.1		Not connected.
IO.24	H2.24		Not connected.
IO.25	H2.23		Not connected.
IO.26	H2.22		Not connected.
IO.27	H2.21		Not connected.
IO.28	H2.20		Not connected.
IO.29	H2.19		Not connected.
IO.30	H2.18		Not connected.
IO.31	H2.17		Not connected.
IO.32	H2.16		Not connected.
IO.33	H2.15		Not connected.
IO.34	H2.14		Not connected.

CubeSat Kit Battery Module 1 (BM 1) Rev A

IO . 35	H2.13		Not connected.
IO . 36	H2.12		Not connected.
IO . 37	H2.11		Not connected.
IO . 38	H2.10		Not connected.
IO . 39	H2.9		Not connected.
IO . 40	H2.8		Not connected.
IO . 41	H2.7		Not connected.
IO . 42	H2.6		Not connected.
IO . 43	H2.5		Not connected.
IO . 44	H2.4		Not connected.
IO . 45	H2.3		Not connected.
IO . 46	H2.2		Not connected.
IO . 47	H2.1		Not connected.

CubeSat Kit Bus PIN DESCRIPTIONS – Analog References

Name	Pin	I/O	Description
VREF0	H1.26		Not connected.
VREF1	H1.28		Not connected.
VREF2	H1.30		Not connected.

CubeSat Kit Bus PIN DESCRIPTIONS – Reserved

Name	Pin	I/O	Description
RSVD0	H1.44		Not connected.
RSVD1	H1.45		Not connected.
PPS ⁴	H1.46		Not connected.

CubeSat Kit Bus PIN DESCRIPTIONS – I2C Bus

Name	Pin	I/O	Description
SDA_SYS	H1.41	I/O	I2C data. To/from each supervisor MCU (an I2C slave device). Typically from the PPM processor.
SCL_SYS	H1.43	I	I2C clock. To each supervisor MCU (an I2C slave device). Typically from the PPM processor.

CubeSat Kit Bus PIN DESCRIPTIONS – Control & Status

Name	Pin	I/O	Description
-FAULT	H1.25		Not connected.
SENSE	H1.27		Not connected.
-RESET	H1.29	I/O	Input to reset supervisors controlling each supervisor MCU.
OFF_VCC	H1.31	I	When resistor RTBD is fitted and no USB power is present, an active signal on this pin will disable VCC_MCU power to each supervisor MCU.

⁴ This signal was formerly called RSRVD2 and was reserved.

CubeSat Kit Bus PIN DESCRIPTIONS – RBF and Separation Switches

Name	Pin	I/O	Description
s0	H2.33 H2.34		TBD
s1	H2.35 H2.36		TBD
s2	H2.37 H2.38		TBD
s3	H2.39 H2.40		TBD
s4	H2.41 H2.42	I/O	Battery voltage, post-RBF. Battery- and EPS-dependent. Varies with state-of-charge of the batteries. Protected against fault conditions by Battery Module.
s5	H2.43 H2.44	I/O	

CubeSat Kit Bus PIN DESCRIPTIONS – Power

Name	Pin	I/O	Description
VBATT	H2.45 H2.46	I/O	Battery voltage, post-RBF. Battery- and EPS-dependent. Varies with state-of-charge of the batteries. Protected against fault conditions by Battery Module.
+5V_USB	H1.32	I	+5V USB power. From USB host.
+5V_SYS	H2.25 H2.26	I	+5V system power. From EPS.
PWR_MHX	H1.33		Not connected.
VBACKUP	H1.42		Not connected.
VCC_SYS	H2.27 H2.28	I	VCC System power. From EPS.
AGND	H2.31		Not connected.
DGND	H2.29 H2.30 H2.32	-	Battery ground.

CubeSat Kit Bus PIN DESCRIPTIONS – Transceiver Interface

Name	Pin	I/O	Description
-RST_MHX	H1.34		Not connected.
-CTS_MHX	H1.35		Not connected.
-RTS_MHX	H1.36		Not connected.
-DSR_MHX	H1.37		Not connected.
-DTR_MHX	H1.38		Not connected.
TXD_MHX	H1.39		Not connected.
RXD_MHX	H1.40		Not connected.

CubeSat Kit Bus PIN DESCRIPTIONS – User-defined

Name	Pin	I/O	Description
USER0	H1.47		Not connected.
USER1	H1.48		Not connected.
USER2	H1.49		Not connected.
USER3	H1.50		Not connected.
USER4	H1.51		Not connected.
USER5	H1.52		Not connected.
USER6	H2.47		Not connected.
USER7	H2.48		Not connected.
USER8	H2.49		Not connected.
USER9	H2.50		Not connected.
USER10	H2.51		Not connected.
USER11	H2.52		Not connected.

Additional Information

TRADEMARKS

The following are Pumpkin trademarks. All other names are the property of their respective owners.

- Pumpkin™ and the Pumpkin logo
- Salvo™ and the Salvo logo
- CubeSat Kit™ and the CubeSat Kit logo

DISCLAIMER

PUMPKIN RESERVES THE RIGHT TO MAKE ANY CHANGES WITHOUT FURTHER NOTICE TO ANY PRODUCTS HEREIN TO CORRECT ERRORS AND IMPROVE RELIABILITY, FUNCTION, APPEARANCE OR DESIGN. PUMPKIN DOES NOT ASSUME ANY LIABILITY ARISING OUT OF THE APPLICATION OR USE OF ANY PRODUCT OR CIRCUIT DESCRIBED HEREIN; NEITHER DOES IT CONVEY ANY LICENSE UNDER ITS PATENT RIGHTS, NOR THE RIGHTS OF OTHERS.



744 Naples Street
San Francisco, CA 94112 USA
tel: (415) 584-6360
fax: (415) 585-7948

web: <http://www.pumpkininc.com/>
email: info@pumpkininc.com

web: <http://www.cubesatkit.com/>
email: info@cubesatkit.com